

Miscellaneous Gripping

Principle

In many cases when using a multi-suction cup installation, some of the cups will not be covered by the product(s) to be handled. This leads to a high risk of reduced grip from the covered suction cups, or may even prevent them gripping at all.

Examples

- Gripping of panels, sheet metal, etc. in a wide variety of sizes by a vacuum lifter equipped with suction cups.

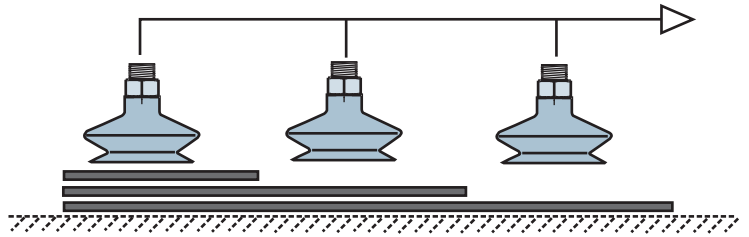

- Uncertain position of the object(s).

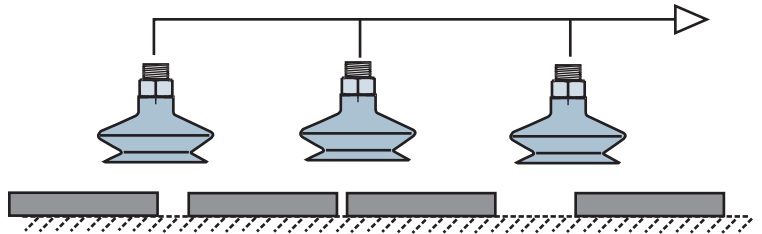

- Gripping several objects at one time, some of which may be missing.

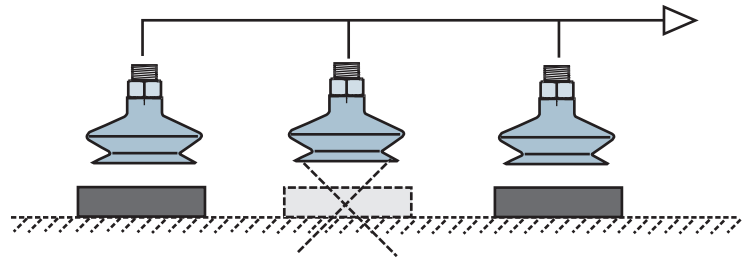

Solutions

- Independent ejector

Mounting an ejector for each suction cup guarantees the installation will operate perfectly even if one or more suction cups are not covered.

The COVAL solutions are the VR, GVR, CVP and CVPC series micro-ejectors.

For further information, see chapter 6.

- Flow control fittings

Flow control fittings are incorporated as part of the suction cup mounting, thus reducing leakage in that cup with no part present during the vacuum cycle.

This technical solution is particularly suitable for vacuum grippers with a large number of suction cups.

To determine the diameter of the nozzle, COVAL has developed a specific CAD.

- Mechanical feelers

See following pages. COVAL offers four solutions depending on the application, with their advantages and drawbacks.

Flow Control Fittings

Groups 1 and 2

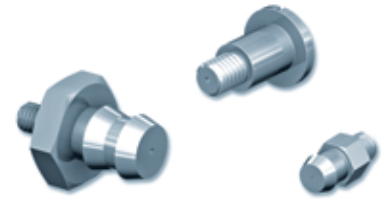

These fittings are designed for installations with a large number of suction cups connected to the same vacuum generator (vacuum gripper technology), particularly in cases where there may be objects missing from the layer of objects to be handled. Using flow-controlled fittings reduces the loss of flow and therefore optimizes the size of the vacuum generator.

Caution, do not use this type of fitting for applications in a dusty environment.

Characteristics

References	ØA	ØD	B	C
IM5 MVSD1.1	M5-M	1.1	8	5
IM21 SP058	M5-M	0.45	4.5	5
IM21 SP094	M5-M	0.6	4.5	5
IM60 SP335	M6-M	0.6	7	11
IM60 SP387	M6-M	1.2	7	11
IM60 SP461	M6-M	0.9	7	11
IM60 SP483	M6-M	1	7	11
IM60 SP510	M6-M	1.7	7	11
IM60 SP511	M6-M	2.5	7	11
IMCM5 D0.6	M5-M	0.6	8	5
IMCM5 SP691	M5-M	1.1	8	5
IMCM5 SP701	M5-M	1.5	8	5

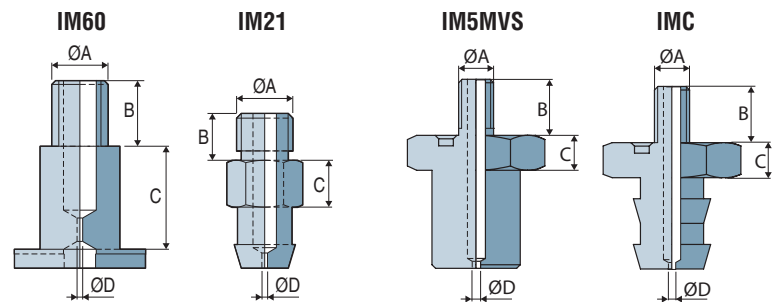

4

Maximum suction per nozzle diameter

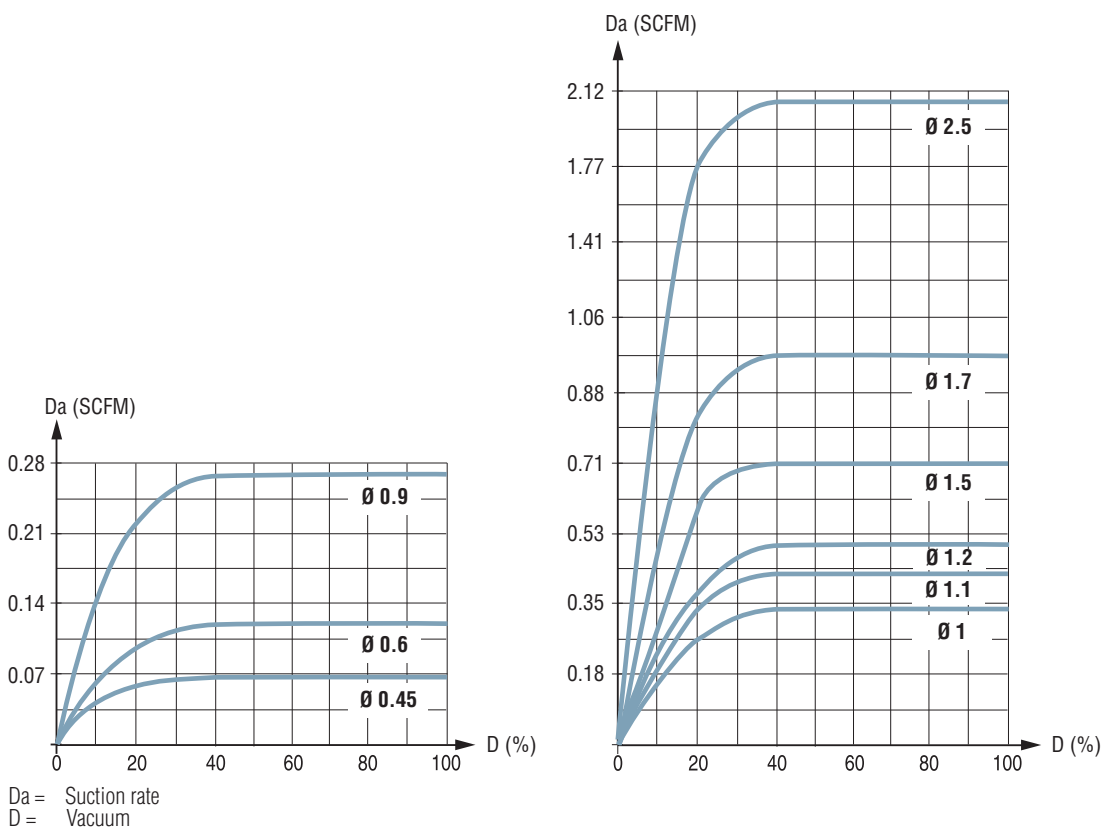

 Please specify the part e.g.: IM60SP387
See part n° table above.

Note: All dimensions are in mm